



PROJECT GUIDELINES – WT_NGK Nutmeg Grinder Kit

Please read fully before starting your project

Every woodturner has their own way of doing things that suits their style and available equipment. Below are guidelines as to how we turn for the WT_NGK. There will be other ways and other equipment that you may prefer to use.

The WTTech Nutmeg Grater Kit is a premium grater mechanism for grating whole nutmegs to get a fresh spice to add a unique and superb flavour to many foods.

To make the kit you will require the following:

- Wood blank 85mm long and minimum 60mm wide
- Drills: 45mm, 30mm, 25mm, 10-12mm & 7mm
- Small drill / awl for screw pilot holes

Although the WT_NGK is specifically designed to be a woodturning kit, it can also be used for flat work with square, hexagonal, octagonal, etc forms. In this case, only the drilling guide and finishing processes in these guidelines will be relevant to you.

The 45mm dimension (A) can be turned on a lathe to the correct dimension if you do not have a drill this size.

The nutmeg grater is different to most other mills – it has a grinding plate fixed at the bottom and there should be a 25mm hole in the side of the wood blank (E) to allow a whole nutmeg to be inserted into the kit when the handle is raised.

The detail below provides the depth, positioning and diameter for the rebates and shaft to be cut.

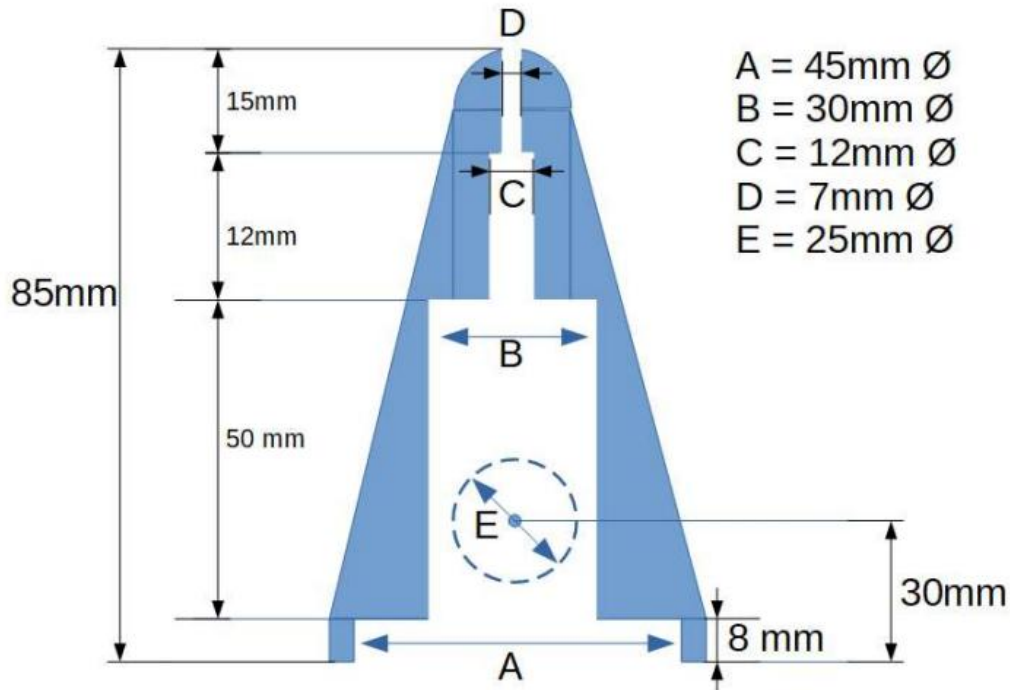

1] We usually start by drilling the side hole 25mmØ half way through the blank. The centre of the drill should be in position E on the dimension diagram.

2] Then drill the remaining holes. This can be done on a pillar drill or mounted on a lathe. Usually Forstner bits are used for the drilling. Start with the 45mm drill and work through the blank reducing the size of each drill until finally the 7mm drill exits the blank. If you do not have a long 7mm drill you can drill that size from the top of the blank. It is very important that the drilling is all straight through the blank. If it is not centred, the shaft will be at an angle and may not work correctly.

3] Once the drilling is complete, the blank can be mounted on a lathe between centres. This is usually done with a scrap of wood mounted in a chuck and turned to a point around 35mm diameter (it fits into the main void in the blank and gives enough space to turn and finish the bottom of the kit when mounted). Use a live centre at the tailstock.

4] Turn the blank to your desired design and sand to one stage before final sanding.

5] Stop the lathe and sand the nutmeg entrance hole by hand. Once this is done, the final sand and finish can be done to the main body with the lathe on again.

6] Add a small amount of finish to the inside of the nutmeg hole so the finish inside the hole and the outside body match.

7] There is no need to add finish inside the main body but you can if you wish. The nutmeg should not come into contact with any wooden parts once inserted.

8] Loosely position the grinder plate in the bottom rebate and mark the position of the 2 screw holes. Drill a suitable sized pilot hole for the screws.

ASSEMBLY

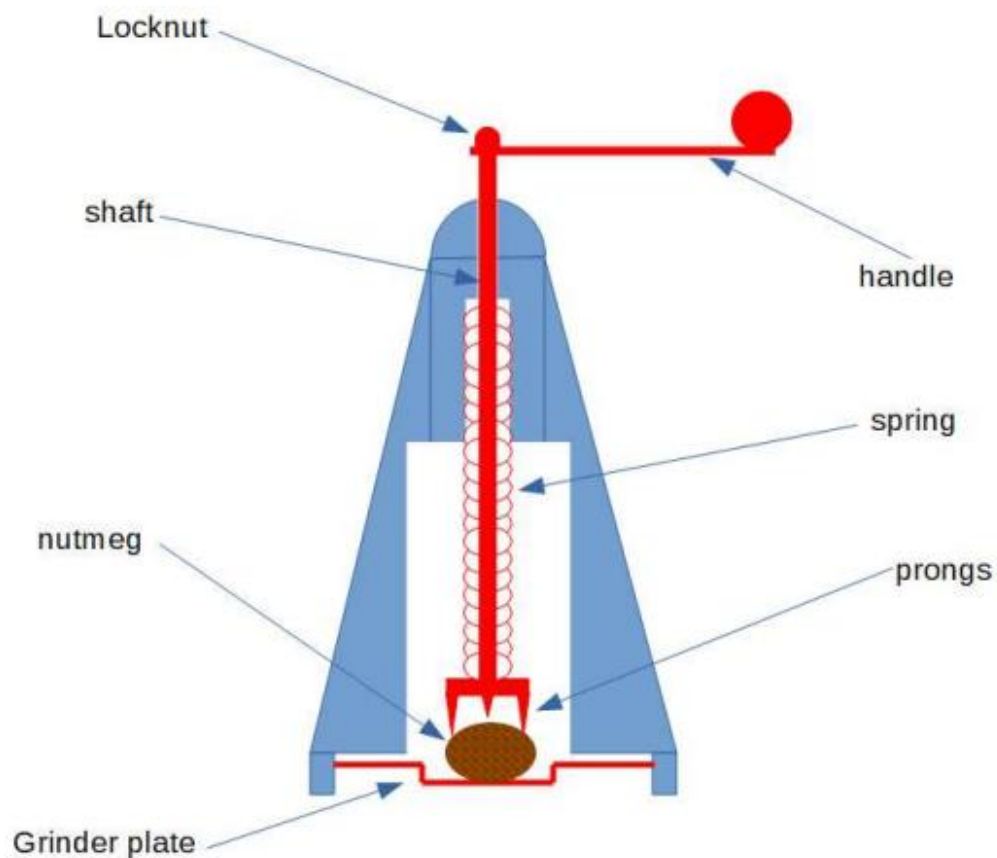

The diagram shows the different parts of the kits – take care when handling the prongs – **they are sharp**.

1] Place the spring over the main shaft and insert it from the bottom of the blank until the thread protrudes from the top (you can use a flat tool for this to save your fingers if needed).

2] Once the thread is sticking out of the top, screw on the handle and then the locking nut.

3] Turn the kit over and screw in the grinder plate ensuring it is the correct way up as per the diagram.

NB: THE PRONGS MUST NOT TOUCH THE GRINDER PLATE WHEN ASSEMBLED OR THEY WILL DAMAGE THE BLADES

HOW TO USE THE GRINDER

Lift the sprung handle (holding as close to the top of the wood as you can), once lifted far enough insert a whole nutmeg through the hole in the side and lower the handle gently. Then turn the handle clockwise, the prongs will grip the nutmeg and turn it on the grinder plate. The grinder plate has 2 different sections - a serrated blade and flat blade to obtain a random grate of the nutmeg which should make it ideal size for use.

We hope you enjoy making and using the kit and are ready to tell everyone who asks what it is when they see it.

MAKERS NOTES

The dimensions given are important for the mechanism to work correctly however it is possible to use a longer blank and make a bigger rebate at the bottom (45mm section) – take care to position your side hole correctly if you do this. Also be aware that the longer the blank the longer reach you will require for the drills in the main body.

If you are using a pillar drill, the kit can be made whatever shape you wish (square, octagonal, etc). It can be made without a lathe if required.

Remember: If you make an error – the kit can be dismantled and re-used with another blank